

# PATRIOT-AT1 LIFT

U.S. PATENT NO'S: [7,249,386 B2] [D507,769 S]

\*MEASUREMENT TAKEN WITH THE LIFT AT FULL LOAD\*

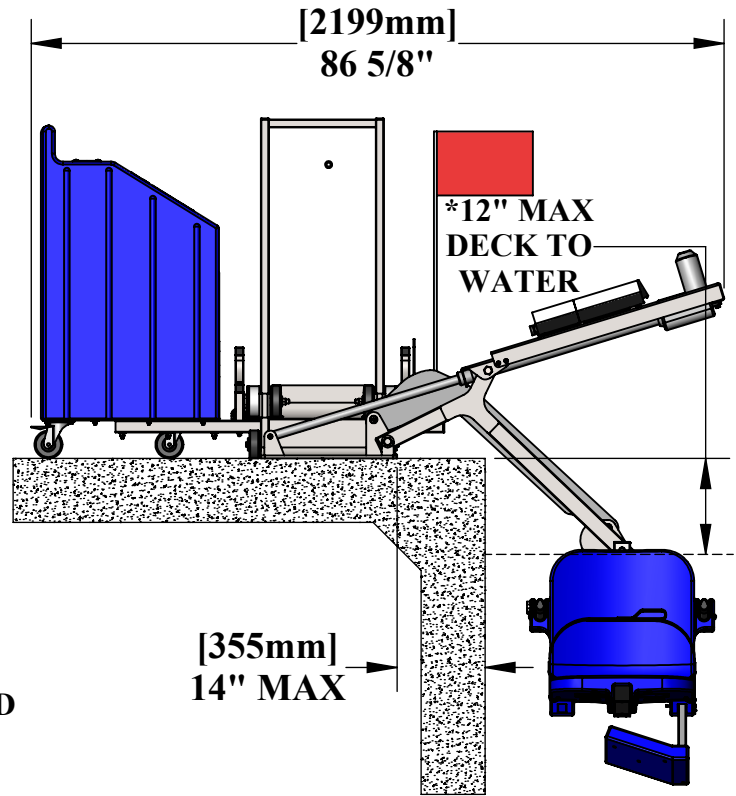
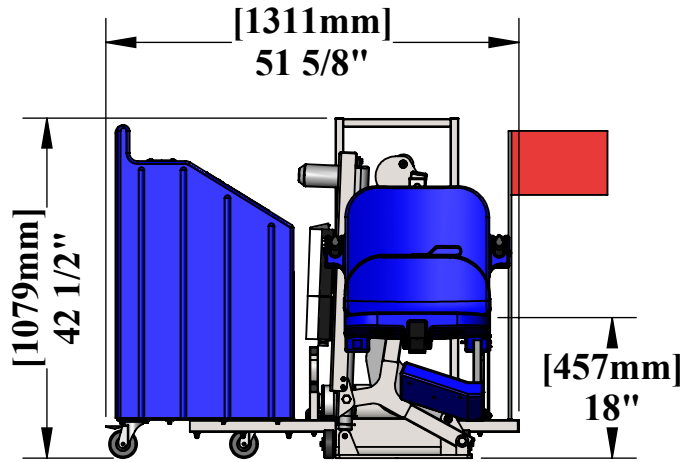

**PRODUCT WEIGHT: 275lbs [124kg]**  
**MAX WEIGHT CAPACITY: 375lbs [170kg]**  
**MIN ANCHOR SETBACK: 9"**  
**MAX ANCHOR SETBACK: 14"**  
**MAX WATER DRAFT: \*12"**  
**ADA COMPLIANCE: THIRD PARTY VERIFIED**  
**BY WYLE LABS**  
**STOWED WIDTH: 35 1/4" (W/O FOOTREST)**

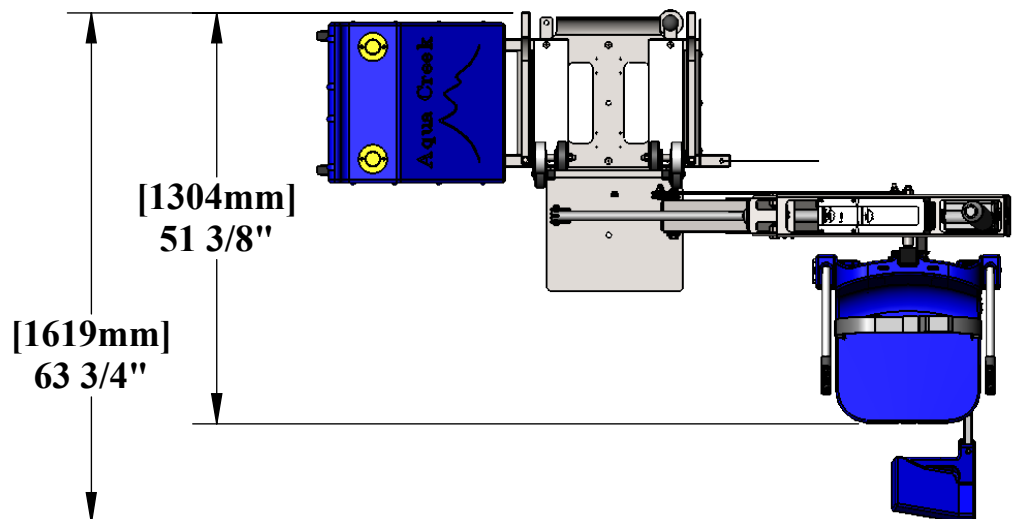
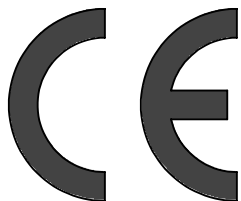
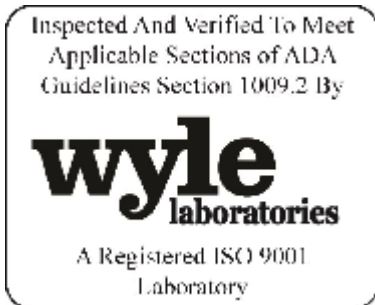

9889 GARRYMORE LANE  
 MISSOULA, MT 59808  
 (406) 549-0769  
 FAX (406) 549-2602

NOTE:  
 \*SPECIFICATIONS ARE SUBJECT TO CHANGE WITHOUT NOTICE

PRODUCT:	PATRIOT-AT1	
PART #:	F-12PPL-HD-AT1	
SCALE:	1:24	DATE: 7/14/2017
DRAWN BY:	KR	REVISION: A